

UNIVERSITY OF NORTH CAROLINA AT CHARLOTTE

Department of Electrical Engineering

Experiment No. _____ Transistor Hybrid Parameters

INTRODUCTION

The mid-frequency equivalent circuit of a transistor biased in a common-emitter configuration is shown below:

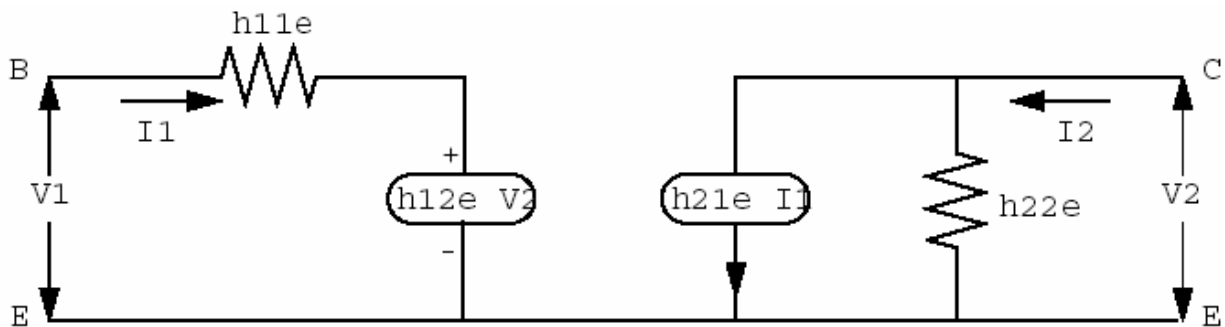

Two forms of a two-port representation of the transistor are shown below:

$$V_1 = h_{11e} I_1 + h_{12e} V_2$$

$$V_2 = h_{12e} I_1 + h_{22e} V_2$$

or

$$I_2 = h_{21e} I_1 + h_{22e} V_2$$

$$I_2 = h_{21e} I_1 + h_{22e} V_2$$

The voltages and currents above are assumed to be small-signal AC parameters.

The h-parameters can be obtained in the following manner,

$$h_{11e} = \left. \frac{\Delta V_1}{\Delta I_1} \right|_{V_2 = 0}^Q$$

$$h_{12e} = \left. \frac{\Delta V_1}{\Delta V_2} \right|_{I_1 = 0}^Q$$

$$h_{21e} = \left. \frac{\Delta I_2}{\Delta I_1} \right|_{V_2 = 0}^Q$$

$$h_{22e} = \left. \frac{\Delta I_2}{\Delta V_2} \right|_{I_1 = 0}^Q$$

The symbol, Q , indicates that the parameters are taken about the quiescent or DC biased point of the transistor. The above hybrid parameters are by no means constant. They vary with biasing conditions, temperature, and frequency.

The purpose of this experiment to determine experimentally the small-signal h-parameters of a common-emitter configured transistor and compare them with typical values.

PRELIMINARY

P-1. Obtain from the manufacturer's specifications the absolute maximum values of the parameters listed below for the 2N3904 (or its equivalent).

Collector-Base Voltage, V_{CBO} : 60V_____
Collector-Emitter Voltage, V_{CEO} : 40V_____
Emitter-Base Voltage, V_{EBO} : 6V_____
Continuous Collector Current: 200mA_____
Continuous Power Dissipation @ 25 C: 310mW_____.

Also sketch the pin-out configuration of the transistor:

Refer manual for pin configuration

P-2. Different combinations of capital and small letters define the different currents and voltages in a transistor. Look these up in any modern electronics textbook and list them below for either current or voltage.

refer pg 376. (Chapter 11 - Low Frequency Amplifiers)

Microelectronics (digital and analog circuits and systems)
Jacob Millman

INSTRUCTOR'S SIGNATURE _____ DATE _____

Suggested Reference

Microelectronics (digital and analog circuits and systems)
Jacob Millman

PROCEDURE

- F-1. Turn on the current source and voltage source of Figure 1 and adjust the current setting of the current source (both vernier and multiplier) and the voltage setting of the voltage source to their lowest settings BEFORE CONNECTING THEM TO THE CIRCUIT. Also set the voltage limit of the current source to 10 volts or less
- F-2. Connect the circuit and make the following adjustments to the sources:
- Voltage source (VCC) = $V_{CEmax}/2$
- Current source (IBB) adjusted so that $I_C = P_{max}/V_{CEmax}$
- Record the quiescent parameters I_{C-Q} , V_{CE-Q} , I_{B-Q} , and V_{BE-Q} .
- F-3. Leaving the current source adjusted as in Procedure F-2 above (I_{B-Q}), adjust the voltage source to 3/4th of V_{CEmax} . Record I_C , I_B , V_{CE} , and V_{BE} .
- F-4. Repeat Procedure F-3 above for the voltage source adjusted to 1/4th of V_{CEmax} .
- F-5. Set the voltage source to V_{CE-Q} and adjust the current source so that the collector current is now 1.5 times I_{C-Q} . Record I_c , I_b , V_{ce} , and V_{be} .
- F-6. Repeat Procedure F-5 above with the current source adjusted so that the collector current is 1/2 of I_{C-Q} .

REPORT

- R-1. Determine the h-parameters from the experimental data obtained in the Procedures above and compare them with typical values.
- R-2. Discuss the results of the experiment; especially the variation of the collector current of the transistor as a function of temperature.

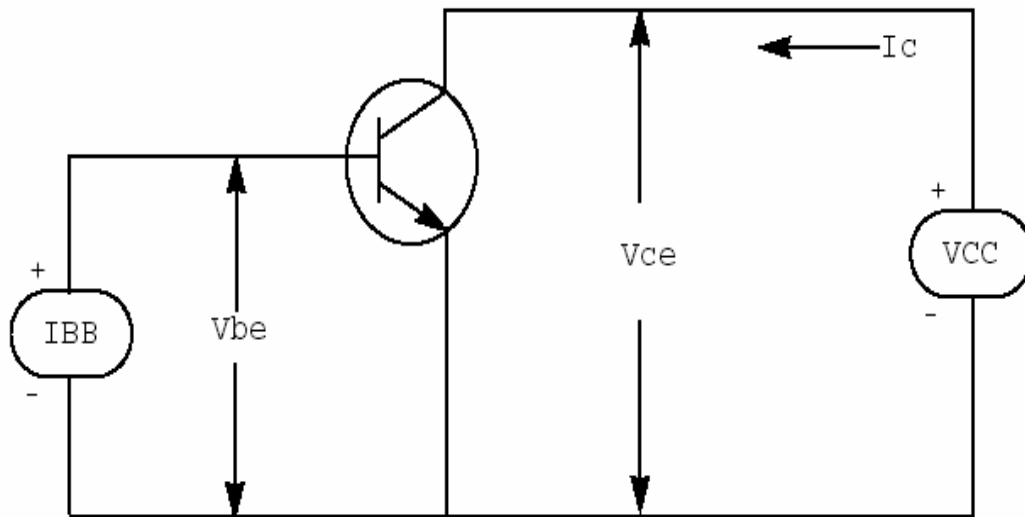

Figure 1

NOTE: REVERSE THE POLARITIES OF THE POWER SUPPLIES IF THE TRANSISTOR IS A PNP TRANSISTOR!